

THE EFFECT OF LOAD AND CYLINDER INCLINATION TO DISPLACEMENT SPEED OF DOUBLE ACTING PNEUMATIC CYLINDER

Heru Sukanto¹

Abstract : The effects of load and alignment of double acting pneumatic cylinder have been investigated. The cylinder used had the stroke length of 320 mm and the bore diameter of 20 mm. The electric circuit with double solenoid valve was selected to control the both extend and retract displacements of cylinder and to on/off of stop watch as well. The friction force was eliminated using bearing construction base.

The results show that the load has no effect to the speed of cylinder stroke in the horizontal, however the speed will decrease linearly with increasing of inclination in both of extend and retract strokes. The speed tends to decrease if the cylinder stroke has to raise the load and it will increase if the cylinder has to descend the load.

The simulation shows that the slower moving of cylinder resulted from either heavier load or higher inclination because the cylinder looks like to accumulate the pressured air before starting movement.

Keyword: pressured air, extend, retract, inclination, pneumatic

LATAR BELAKANG

The pneumatic technology has been applied widely in automation industries and continuously developed until recent day of PLC. However, application of this system requires a lot of integrated consideration such as cylinder type and dimension, tube size, control valve type, load has to be handled, working air pressure, etc. Therefore, it is necessary to do perfect design and calculation in technology and economic aspects before determining the pneumatic system as solution in business.

In this paper will be discussed the change of extend and retract strokes speed of double acting cylinder because of cylinder load and inclination variations. The speed which it has the same sense with the time is an important thing in automatic system. All of mechanisms included in automation have to work in the right time to establish the synergistic and correct sequence movements.

¹Staf Pengajar Teknik Mesin FT, UNS

Experiment Design

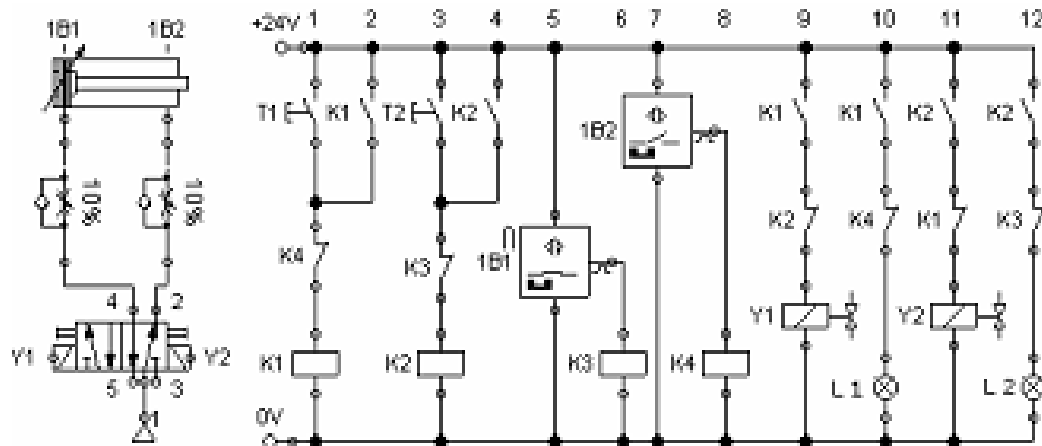

Figure 1. Electrical circuit used in the experiment.

The cylinder used in this experiment was governed of its motions via indirect electrical control as shown in figure 1. The cylinder was mounted on the anvil that it has a function as hinge with ball bearing slider attached to support the mass movement that the friction may be neglected. Considering to fig.1, T1 push button has a function as an initial signal generation in order to extend the rod cylinder. In the same time of pushing T1, the lamp L1 will be lighted as an indication that the time measurement has been started. After cylinder reach the fully extend position, the sensor 1B2 will be on to finish the rod cylinder outstroke and stop the time counting as well. At this last position, the cylinder is ready to retract by pushing T2. Time measurement during retraction is indicated by L2 and stopped by 1B1 sensor. The table below shows the specification list of the components used.

Item	Specification
Cylinder	double act; bore dia. 20mm; stroke length 320 mm
Control valve	5/2 double solenoids
Flow control	Screwed 10% open
Tube	4 x 0,75; 1 m length
Fitting	quick push in
Loads setting	0; 2.5; 5; 7.5; 10 kg
Angles orientation	0; 45; 90; 270; 315
Working air pressure	6 bar
Sensor position	magnetic

Results and Discussion

The experiment provides average speed of cylinder stroke by mean of dividing the time required the cylinder to fully extend or retract from cylinder stroke length. Generally, the retraction has slower speed than extension because of the cross section area where the pressured air must push the piston is narrower as consequence of presenting of rod diameter.

The increasing load will tend to decrease the speed if the cylinder is mounted with inclination. However, it has no significant effect if the cylinder is installed on horizontal construction (fig.2). It is make a sense because of the load may produce the gravity force if it has an angle to the horizontal. Thus, the heavier load creates higher gravity force and need the larger force of cylinder to lift it up. The opposite result occurs when the load has to be descended; that is the increasing load makes the displacement the cylinder rod to be faster. In this case, the gravity force works in the same direction to the cylinder force. Thus the load instead to add the force generated by pressured air supply (fig.3).

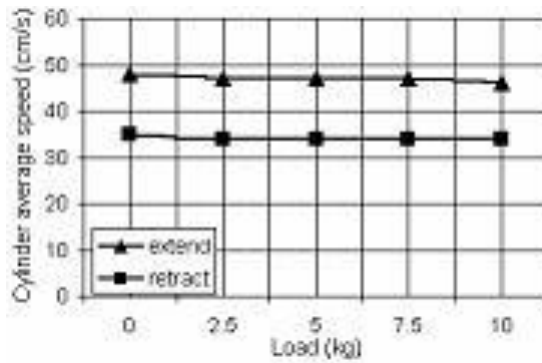

Fig. 2. Graphic of the load variation effect to the cylinder average speed without inclination

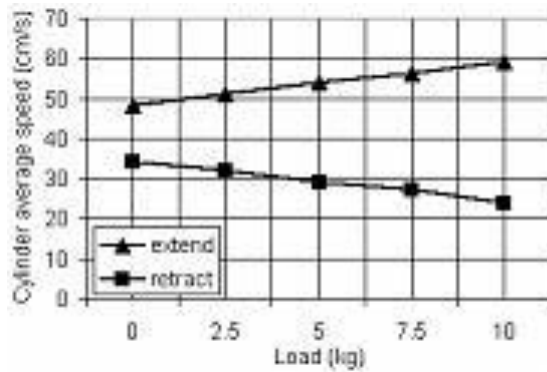

Fig.3. Graphic of the load variation effect to the cylinder average speed with angle orientation of 315°.

Considering fig.2 as a datum and fig.3 as variable, for inclination angle of 315° provides increasing extension average speed of 3 cm/s every adding the load of 2,5 kg that has to descend. In the other hand, the retraction average speed will be reduced for about 2 cm/s every increment loads of 2,5 kg that to be lifted. When the extension displacement of cylinder has to be used to lift the load and the retraction stroke is applied to descend the load (cylinder is orientated to 45°), there are no changes in speed reduction or speed addition.

The effect of inclination angles with load of 10 kg, 5 kg, and without load are shown in figure 4, 5 and 6 respectively. From these graphics, the angle of -90° and -45° represent to the inclination of 270° and 315°. It can be seen that the load has a significant effect to the graphic slope. Decreasing or increasing speed tend to make a nearly linear line with degree of inclination. However, the displacement speed of cylinder without load is very close to constant in every point of inclination degree. It can be understood because of no gravity force that it has to be pushed or pulled.

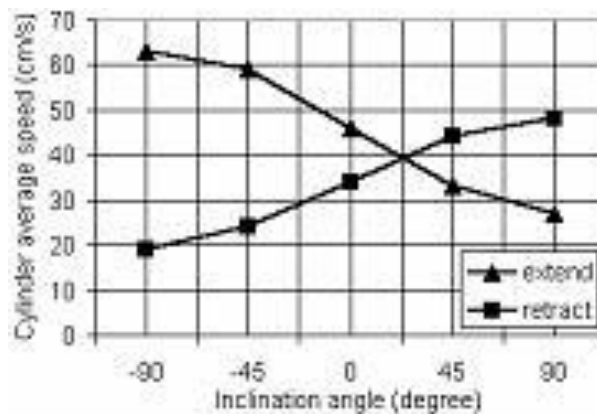

Fig.4. Effect of inclination angle to cylinder average speed with load of 10 kg

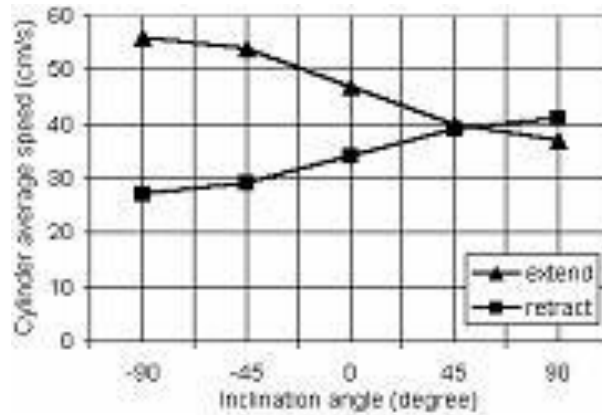

Fig.5. Effect of inclination angle to cylinder average speed with load of 5 kg

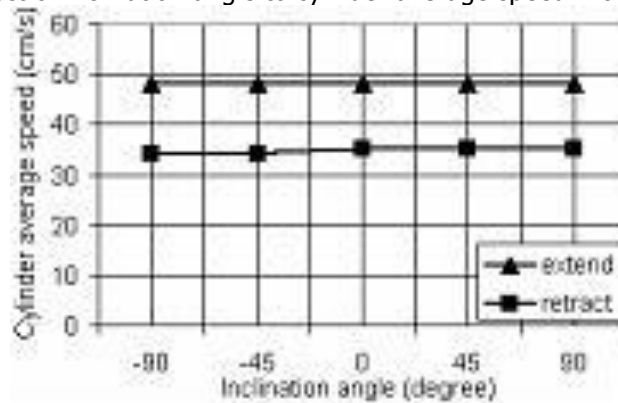

Fig.6. Effect of inclination angle to cylinder average speed without load.

The lines of extend and retract for variation loads tend to intersect in certain pattern. Heavier load will shift the intersection point to the horizontal when the extending displacement is serviced to lift the load and retracting for descending. However, the intersection point will be not created when the cylinder retracting is used to lifting the load and extending movement for descending. Even, the gap of speed of retraction and extension strokes will be greater if the load and the inclination angle are increased. The other interesting result is that two lines on graphics of fig.4 and fig.5 intersect at level of cylinder speed of around 40 cm/s in any loads and inclination angles. It means that in the condition of intersection point it can be considered to construct cylinder in either retraction or extension stroke, it has no effect to speed.

The phenomena of speed and pressure behaviors may be demonstrated by Pro-Pneu software. Fig.7 and fig.8 show the simulation results provided by the software with parameters described on figure title. It can be seen that the cylinder speed has no constant value during start to reach the end position. It is fluctuated and correlated to the air pressure that it is delivered into or flowed away from cylinder via control valve ports.

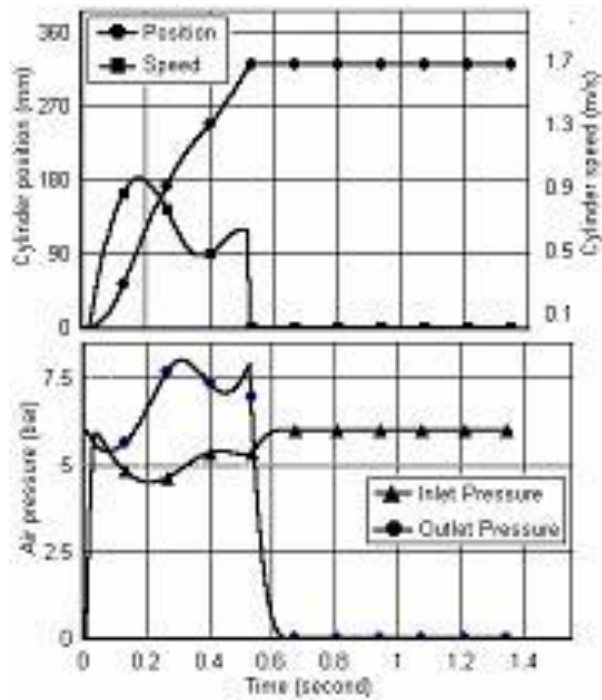

Fig.7. Graphics of cylinder extension speed and air pressures behavior (7.5 kg, 270°)

In initial movement, the pressured air has to against the opposite forces created by friction between seal and cylinder wall and the load as well. The other burden is the residual outlet air pressure that takes a place in the front of piston displacement. Theoretically, this air pressure has to be released to the atmosphere freely and simultaneously as the switching position of valve control is reversed. However, this request will be carried out if there is no air flow control installed or no adjustment cylinder speed needed. When the cylinder speed has to be controlled, the debit of output air from cylinder must be adjusted and the input air lets be free to flow into cylinder.

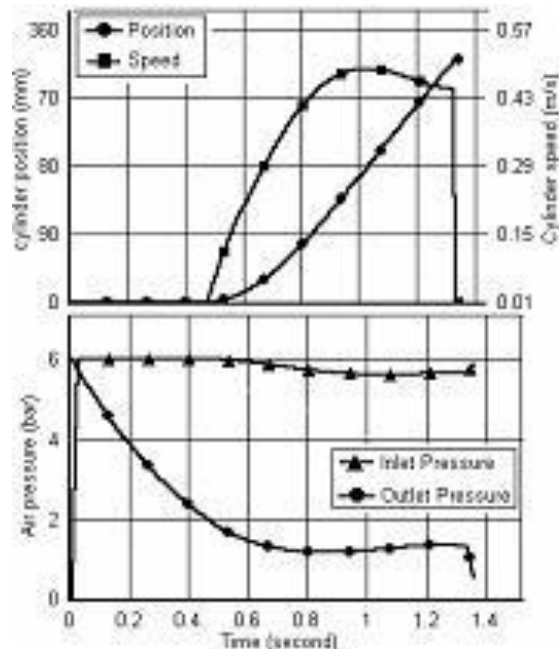

Fig.8. Graphics of cylinder retraction speed and air pressures behavior (10 kg, 315°)

In the case of fig.7, the load acts in the same direction to air pressured force and as a result is that the cylinder speed will be high. It is true in the initial stroke because the piston will move almost at the same time to the switching position control valve change. As shown in figure, at the first time the speed exhibits significant raising until for about 95 cm/s because of

the exhaust air pressure going to drop at this time. The over speed of cylinder piston tend to increase the outlet air pressure resulted from restriction of output debit by flow control. In the other word, reducing volume in front of cylinder is faster than the releasing air pressure. It means that the cylinder will carry the adding load that leads to reduce the cylinder speed, as depicted by fig.7.

In the case of the load must be lifted and the cylinder speed has to be adjusted, figure 8 may be used as explanation. After control valve receives a command to make cylinder retraction, the cylinder does not move immediately because of the air pressure supply has no ability to lift the loads yet. Air pressure will be supplied continuously and at the same time the outlet pressure going to down until the certain level. After the outlet air pressure does not act as load, the cylinder begins to move slowly. The inlet and outlet air pressures tend to at certain level after a moment of moving cylinder. It means that the volume change inside of cylinder nearly equals to inlet and outlet air debits.

Conclusion

- 1. The increasing load has no effect in both extension and retraction of horizontal cylinder displacement speed if the friction between load and base is to be zeroed. The influence of load to the cylinder speed will appear if the load is installed with inclination on the cylinder.**
- 2. The cylinder does not move in the constant speed from initial to the end stroke.**
- 3. For the certain load and inclination angle the extension and retraction displacement give the same speed.**

References:

1. Croser P, Ebel F, 2002, *Pneumatic Basic Level*, PT. Festo
2. Waller D, Werner H, Ocker Th, 2002, *Electro-pneumatic Advance Level*, PT. Festo.
3. Patient P, Pickup R, Powell N, 1985, *Modular Course in Technology Pneumatics*, Longman Group Ltd, UK
4. Pro-Pneu Software
5. Fluid-SIM 3D Software